

ROSE



ANY QUESTIONS?

rosebikes.de/support

ROSE Bikes GmbH
Schersweide 4
46395 Bocholt, Germany
www.rosebikes.de

P D Q A L

FRAME DETAILS

FRAME DETAILS

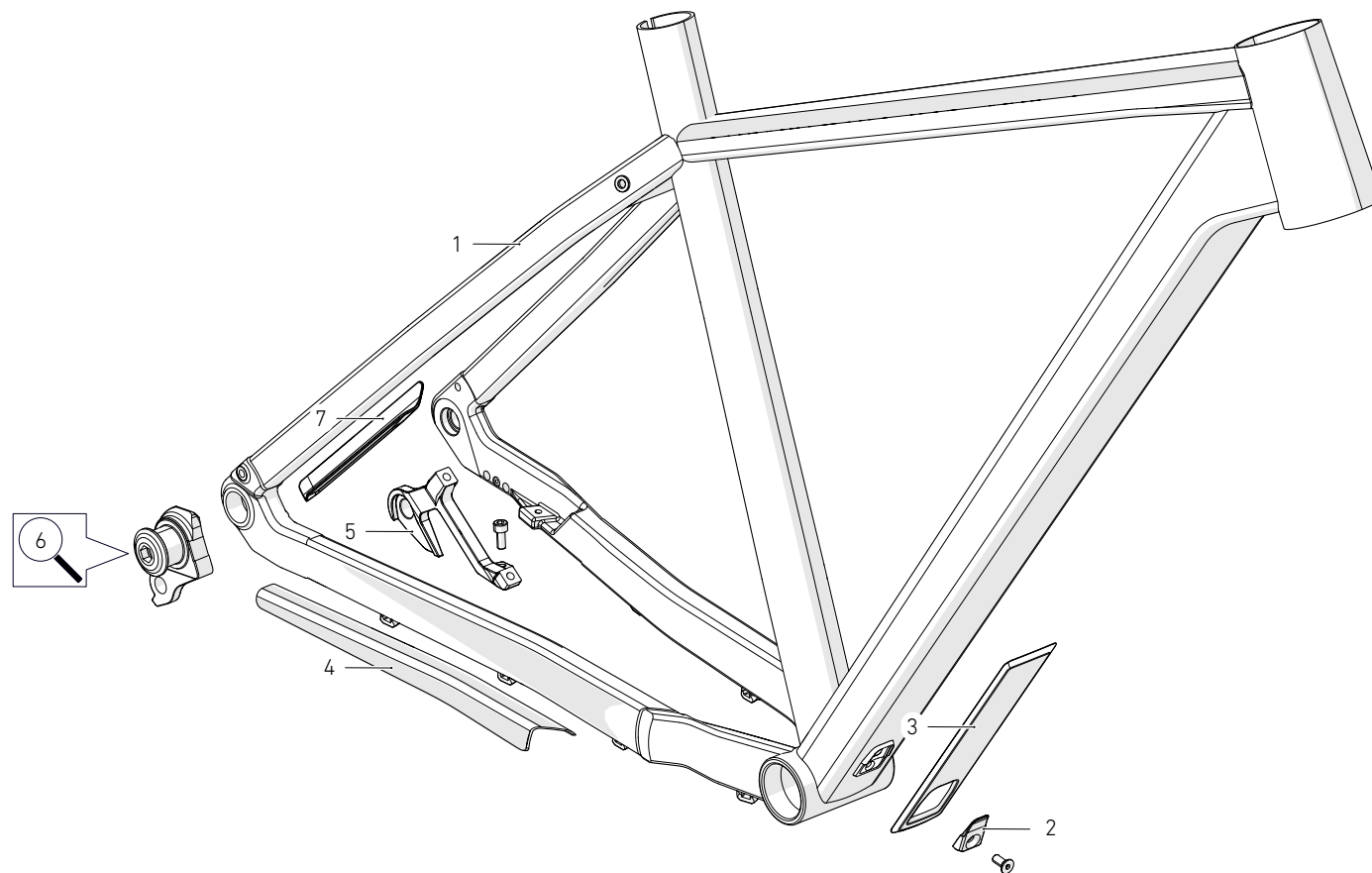
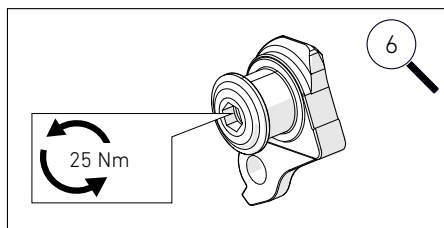

FRAME SPARE PARTS

POS.	DESCRIPTION	SPECIFICATIONS	ART. NR.
1	frame	soil	2347607
2	cable outlet cover screw M5x16mm		231095401
3	frame protector		235137801
4	chainstay protector		235190801
5	brake adapter	including screw	1605000001
6	derailleur hanger	SRAM UDH	230116501
7	seatstay protector		231613701

FRAME DETAILS

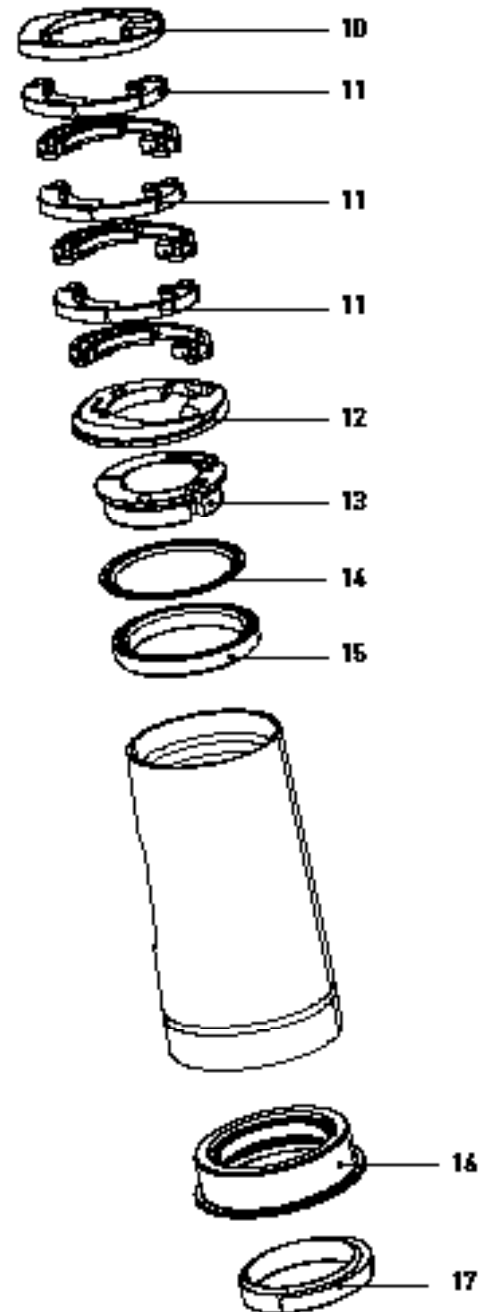

HEADSET SPARE PARTS

POS.	DESCRIPTION	SPECIFICATIONS	ART. NR.
headset			232283401
10	top cover		
11	1/2 spacer	5mm	
12	headtube cover		
13	compression ring	1,125", AC4252	
14	upper headset sealing	AC4252	
15	angular contact bearing	42x52x7, R2	
16	AS bearing cup	ZS56, blocklock	
17	crown race	1,5", blocklock 150°	

P D Q A L

FRAME DETAILS

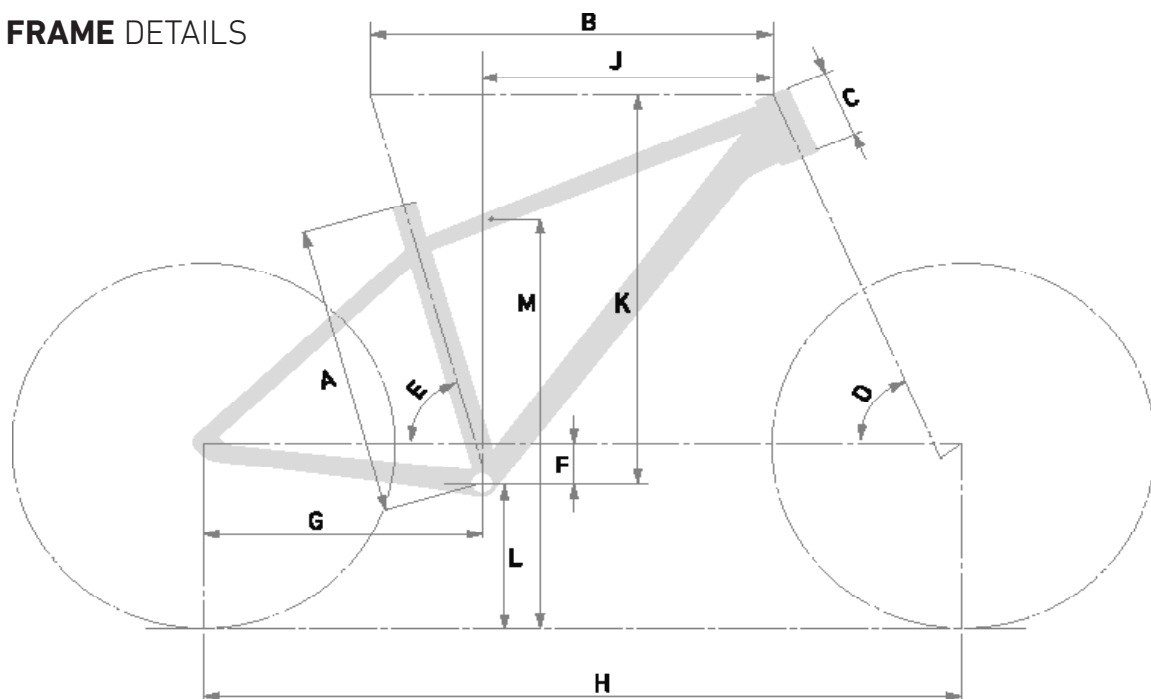

FRAME GEOMETRY

SIZE		XS	S	M	L	XL
SEATTUBE LENGTH [MM]	A	390	420	450	480	510
TOPTUBE LENGTH HORIZONTAL [MM]	B	536,5	570	598	626,5	655
HEAD TUBE LENGTH	C	100	115	100	115	130
HEAD TUBE ANGLE	D	67°	67°	67°	67°	67°
SEAT TUBE ANGLE	E	74,5°	74,5°	74,5°	74,5°	74,5°
BB DROP [MM]	F	55	55	65	65	65
REAR CENTER [MM] (CHAINSTAY LENGTH)	G	425	430	435	440	445
WHEELBASE [MM]	H	1084	1125	1165	1202	1237
REACH [MM]	J	380	410	435	460	485
STACK [MM]	K	605,5	619,5	630,5	644,5	658
BB HEIGHT [MM]	L	301,5	301,5	311,5	311,5	311,5
STANDOVER HEIGHT [MM]	M	729	749	773	798	820

FRAME INTERFACES

BOTTOM BRACKET	BSA 73
HEADSET	IS42 / ZS56
REAR WHEEL AXLE	length: 180 mm, M12x1.0, thread length 13 mm Art. Nr. 230185901 - Sram Maxle Stealth
DERAILLEUR HANGER	SRAM UDH, Art.Nr. 230116501
REAR BRAKE MOUNT	PM180
MAX Ø DISC BRAKE	203 mm
REAR HUB SPACING	12x148 mm
Ø SEATPOST	31.6 mm, internal dropper compatible
Ø SEATPOST CLAMP	36 mm, e.g. ROSE seat post clamp, Art. Nr. 226113801
MAX. TIRE WIDTH	2.4"
WHEEL SIZE	XS-S 27,5" M-XL 29"
MAX. CHAINRING SIZE	36T
CHAIN GUIDE MOUNT	no
BOTTLE CAGE	yes, 1x

MAX SYSTEM WEIGHT (RIDER + BICYCLE + CLOTHING + GEAR + LUGGAGE): 120 KG

INTENDED USE: DIN 17406 CATEGORY 3